



A Series Electric Forklift Truck

with capacities of 4,000 to 4,990kg



HANGCHA GROUP CO., LTD.

Factory site: 666 Xiangfu Road,
Hangzhou, Zhejiang, China (311305)

Tel: +86-571-88926735 88926755
Fax: +86-571-88926789 88132890

sales@hcforklift.com
www.hcforklift.com



Follow us on
Facebook



Follow us on
YouTube



Follow us on
WeChat



Download "Hangcha
Forklift" App



ISO45001
ISO45001:2018



ISO14001
ISO14001:2015



ISO9001
ISO9001:2015



HANGCHA trucks conform
to the European Safety
Requirements.

2025 VERSION 11/COPYRIGHT 2025/01

HANGCHA GROUP CO., LTD. reserves the right to make any changes without notice concerning colors, equipment, or specifications detailed in this brochure, or to discontinue individual models. The colors of trucks, delivered may differ slightly from those in brochures.

The World of Hangcha





High Performance

- / Electromagnetic brake is used as service brake, instead of traditional hand brake, which realizes intelligent parking brake, with lower labor intensity of the operator, and higher safety.
- / Soft landing system lowers descending speed automatically when fork reaches the height range of 100-60mm from the ground, so as to reduce vibration of the entire truck, and provide effective protection for goods.
- / Full AC configuration includes AC traction motor + AC pump motor; With higher performance of entire truck, and longer battery life.
- / Efficient driving control system of high-frequency MOSFET integrated controller guarantees smooth and accurate control on driving and lifting, superior speed regulation performance, with regenerative braking, reverse braking, anti-slipping on slope and other functions, resulting in more efficient, safer, and more comfortable operations.
- / The application of load sensing hydraulic power steering technology realizes reliable, sensitive, and easy steering; distribution of optimized oil in steering oil circuit and working oil circuit increases efficiency of hydraulic system.
- / LED lights for entire truck reduce energy consumption.

Appearance

- / It follows the entire profile of appearance of A series, with clear lines on side of the truck, and smooth transition to counter weight. These lines are shaped as an integral whole, with powerful visual tension.

Maintenance

- / Fully-openable cover enables easy maintenance of battery.
- / Easy-to-open airtight cover plate realizes easier debugging and maintenance of electric control system, and avoids the system from invasion of rain and dust.
- / The brushless, maintenance-free AC drive motor reduces operation cost significantly.
- / The option of side roll out battery is very convenient for fast, efficient, and safe replacement of battery, and is suitable for continuous work conditions.



Comfort

- / The adjustable, small-diameter steering wheel with tilt designed based on ergonomics offers good hand feeling, and the seat can also be adjusted forward and backward, which can provide best driving position for the operator.
- / Head-up display are applied to increase visibility, operability of meters, thus with higher driving safety.
- / Silent running of entire truck, with extremely small vibration, offers more comfortable acoustical environment for the operator.
- / Integrated control valve makes levers be placed at the most comfortable position for hands, resulting in lower labor intensity of the operator.

Stability

- / The internationally advanced parallel arrangement is adopted for traction motor, and the battery is sunken to chassis, resulting in lower gravity center and better stability of entire truck.
- / Flexible steering system, with smaller turning radius, allows stable turnaround within confined passageway.

Reliability & Safety

- / Major electrical components such as motor controller, contactor, power plug, and emergency power off switch are all of foreign famous brands.
- / Major load bearing parts such as carriage, drive axle, steering axle, and mast are all designed with high strength to satisfy high-strength work conditions.
- / As a standard configuration, the emergency power off switch complies with European safety standards.
- / Dual overload protection systems of electronic and hydraulic modes are adopted.



Ergonomic design



Easy to see display



Easy for maintenance



Smaller turning radius

Simple/
Solid/
Smart



Standard Specification

- / High efficiency AC driving motor
- / Multi-functions instrument
- / Rubber floor mat
- / PC Platfond
- / Emergency disconnect switch
- / Pneumatic tyre
- / Electronic parking brake
- / Battery slung removing
- / 2-way-valve
- / LED combination headlight
- / LED rear combination light
- / Panoramic rearview mirror (in the middle position of the overhead guard)
- / 3 meters duplex mast
- / Adjustable steering column
- / Full electronic controlled traveling, lifting and steering
- / Horn and reversing buzzer
- / File folder
- / CAN-BUS system
- / Low noise gear pump (Brand: Shimadzu, Made in Japan)
- / Full hydraulic power steering
- / Soft landing system
- / OPS system

Options

- / Solid tyre
- / Non-marking tyre
- / 3rd or 4th hydraulic function
- / 2.5-5 meters duplex mast
- / 4.0-6 meters triplex mast
- / Rear working LED light
- / Reversing assist grip with horn button
- / Integrated side shift
- / Other attachments
- / Other dimension forks
- / Special carriage and backrest
- / Big capacity battery
- / Battery side roll-out
- / Fingertip control on the adjustable armrest
- / Suspension seat
- / Cold store protection
- / Full closed cabin
- / Blue spot light
- / Alarm lamp
- / Lateral rearview mirror
- / Toolbox

4.0t A Series Mast Specification

Type	Max. fork height	Lowered	Overall height		Free lift		Tilting range		Capacity	
			With backrest	Without backrest	With backrest	Without backrest	F	R	Load capacity at 500mm	
			mm	mm	mm	mm	(°)	(°)	Single tire	Double tire
STD Duplex	2500	1935	3670	3270	150	150	6	11	4000	4000
	2700	2035	3870	3470	150	150	6	11	4000	4000
	3000	2185	4170	3770	150	150	6	11	4000	4000
	3300	2335	4470	4070	150	150	6	11	4000	4000
	3500	2435	4670	4270	150	150	6	11	4000	4000
	3600	2485	4770	4370	150	150	6	11	4000	4000
	4000	2735	5170	4770	150	150	6	11	4000	4000
	4300	2900	5470	5070	150	150	6	6	4000	4000
	4500	3010	5670	5270	150	150	6	6	4000	4000
	4800	3175	5970	5570	150	150	6	6	4000	4000
Full Free lift	2500	1916	3670	3305	750	1115	6	11	4000	4000
	2750	2040	3920	3555	873	1238	6	11	4000	4000
	3000	2166	4170	3805	1000	1365	6	11	4000	4000
Triplex	3300	2316	4470	4105	1150	1515	6	11	4000	4000
	4000	2045	5170	4805	875	1218	6	12	4000	4000
	4300	2145	5470	5105	975	1318	6	6	4000	4000
	4500	2210	5670	5305	1043	1380	6	6	4000	4000
	4700	2275	5870	5505	1105	1445	6	6	4000	4000
	4800	2305	5970	5605	1135	1478	6	6	4000	4000
	5000	2375	6170	5805	1205	1548	6	6	3800	4000
	5500	2540	6670	6305	1373	1710	3	6	3700	3800
6000	2755	7170	6805	1585	1928	3	6	3600	3700	

4.5t A Series Mast Specification

Type	Max. fork height	Lowered	Overall height		Free lift		Tilting range		Capacity	
			With backrest	Without backrest	With backrest	Without backrest	F	R	Load capacity at 500mm	
			mm	mm	mm	mm	(°)	(°)	Single tire	Double tire
STD Duplex	2500	1935	3670	3270	150	150	6	11	4500	4500
	2700	2035	3870	3470	150	150	6	11	4500	4500
	3000	2185	4170	3770	150	150	6	11	4500	4500
	3300	2335	4470	4070	150	150	6	11	4500	4500
	3500	2435	4670	4270	150	150	6	11	4500	4500
	3600	2485	4770	4370	150	150	6	11	4500	4500
	4000	2735	5170	4770	150	150	6	11	4500	4500
	4300	2900	5470	5070	150	150	6	6	4500	4500
	4500	3010	5670	5270	150	150	6	6	4500	4500
	4800	3175	5970	5570	150	150	6	6	4450	4500
Full Free lift	2500	1916	3670	3305	750	1115	6	11	4500	4500
	2750	2040	3920	3555	873	1238	6	11	4500	4500
	3000	2166	4170	3805	1000	1365	6	11	4500	4500
Triplex	3300	2316	4470	4105	1150	1515	6	11	4500	4500
	4000	2045	5170	4805	875	1218	6	12	4500	4500
	4300	2145	5470	5105	975	1318	6	6	4500	4500
	4500	2210	5670	5305	1043	1380	6	6	4400	4500
	4700	2275	5870	5505	1105	1445	6	6	4300	4500
	4800	2305	5970	5605	1135	1478	6	6	4300	4400
	5000	2375	6170	5805	1205	1548	6	6	4200	4300
	5500	2540	6670	6305	1373	1710	3	6	4000	4200
6000	2755	7170	6805	1585	1928	3	6	3800	4000	

4.99t A Series Mast Specification

Type	Max. fork height	Lowered	Overall height		Free lift		Tilting range		Capacity	
			With backrest	Without backrest	With backrest	Without backrest	F	R	Load capacity at 500mm	
			mm	mm	mm	mm	(°)	(°)	Single tire	Double tire
STD Duplex	2500	1935	3670	3270	150	150	6	11	4990	4990
	2700	2035	3870	3470	150	150	6	11	4990	4990
	3000	2185	4170	3770	150	150	6	11	4990	4990
	3300	2335	4470	4070	150	150	6	11	4990	4990
	3500	2435	4670	4270	150	150	6	11	4990	4990
	3600	2485	4770	4370	150	150	6	11	4990	4990
	4000	2735	5170	4770	150	150	6	11	4990	4990
	4300	2900	5470	5070	150	150	6	6	4950	4990
	4500	3010	5670	5270	150	150	6	6	4900	4990
	4800	3175	5970	5570	150	150	6	6	4800	4900
Full Free lift	2500	1916	3670	3305	750	1115	6	11	4990	4990
	2750	2040	3920	3555	873	1238	6	11	4990	4990
	3000	2166	4170	3805	1000	1365	6	11	4990	4990
Triplex	3300	2316	4470	4105	1150	1515	6	11	4990	4990
	4000	2045	5170	4805	875	1218	6	11	4990	4990
	4300	2145	5470	5105	975	1318	6	6	4900	4990
	4500	2210	5670	5305	1043	1380	6	6	4800	4900
	4700	2275	5870	5505	1105	1445	6	6	4700	4900
	4800	2305	5970	5605	1135	1478	6	6	4700	4800
	5000	2375	6170	5805	1205	1548	6	6	4600	4700
	5500	2540	6670	6305	1373	1710	3	6	4400	4600
6000	2755	7170	6805	1585	1928	3	6	4100	4300	

A Series Electric Forklift Truck

		HANGCHA GROUP CO.,LTD.				
Distinguishing mark	1.1	Manufacturer (abbreviation)				
	1.2	Manufacturers type designation	CPD40-AC6*	CPD45-AC6*	CPD50-AC6*	
	1.3	Drive: electric (battery or mains), diesel, petrol, fuel gas	electric	electric	electric	
	1.4	Operator type: hand, pedestrian, standing, seated, order-picker	seated	seated	seated	
	1.5	Load capacity/rated load	Q (kg)	4000	4500	4990
	1.6	Load centre distance	c (mm)	500	500	500
	1.8	Load distance, centre of drive axle to fork	x (mm)	550	550	555
	1.9	Wheelbase	y (mm)	1970	1970	1970
	Weight	2.1	Service Weight	kg	6700	6950
2.2		Axle loading, laden front/rear	kg	9530/1170	10250/1200	10980/1240
2.3		Axle loading, unladen front/rear	kg	3290/3410	3330/3620	3335/3885
Tyres, chassis	3.1	Tyres: solid rubber, superelastic, pneumatic, polyurethane	pneumatic	pneumatic	pneumatic	
	3.2	Tyre size, front		250 - 15	250 - 15	28x12.5 - 15
	3.3	Tyre size, rear		23x10 - 12	23x10 - 12	23x10 - 12
	3.5	Wheels, number front rear (x = driven wheels)		2x/2	2x/2	2x/2
	3.6	Tread, front	b10 (mm)	1150	1150	1166
	3.7	Tread, rear	b11 (mm)	1175	1175	1175
	4.1	Tilt of mast/fork carriage forward/backward	Grad	6/11	6/11	6/11
Dimensions	4.2	Height, mast lowered	h1 (mm)	2185	2185	2185
	4.3	Free lift	h2 (mm)	150	150	150
	4.4	Lift	h3 (mm)	3000	3000	3000
	4.5	Height, mast extended	h4 (mm)	4170	4170	4170
	4.7	Height of overhead guard STD.	h6 (mm)	2310	2310	2310
	4.8	Seat height/stand height	h7 (mm)	1240	1240	1240
	4.12	Coupling height	h10 (mm)	350	350	350
	4.19	Overall length	l1 (mm)	3997	3997	4042
	4.20	Length to face of forks	l2 (mm)	2927	2927	2972
	4.21	Overall width	b1 (mm)	1440	1440	1470
	4.22	Fork dimensions	s/e/l (mm)	50/122/1070	50/150/1070	55/150/1070
	4.23	Fork carriage DIN 15 173 --- ISO 2328, class/type A,B		ISO2328 3A	ISO2328 3A	ISO2328 3A
	4.24	Fork-carriage width	b3 (mm)	1250	1250	1250
	4.25	Distance between fork-arms	b5 (mm)	310/1250	310/1250	310/1250
	4.31	Ground clearance, laden, below mast	m1 (mm)	110	110	110
	4.32	Ground clearance, centre of wheelbase	m2 (mm)	150	150	150
	4.33	Aisle width for pallets 1000 x 1200 crossways	Ast (mm)	4390	4390	4430
	4.34	Aisle width for pallets 800 x 1200 crossways	Ast (mm)	4590	4590	4630
	4.35	Turning radius	Wa (mm)	2640	2640	2675
4.36	Internal turning radius	b13 (mm)	810	810	810	
Performance Data	5.1	Travel speed, laden/unladen	km/h	14/14	13.5/14	13/13.5
	5.2	Lift speed, laden/unladen	mm/s	270/430	260/420	250/400
	5.3	Lowering speed, laden/unladen	mm/s	430/480	440/480	440/480
	5.5	Drawbar pull, laden/unladen	N	16400/17000	15600/16200	15200/15600
	5.6	Max. Drawbar pull, laden/unladen	N	24000	26000	27000
	5.7	Gradeability, laden/unladen	%	14.5/15.5	14/15	13/14
	5.8	Max. gradeability, laden/unladen	%	16/28	15/27	14/25
	5.9	Acceleration time, laden/unladen (0-10m)	s	5.2/5.4	5.3/5.5	5.4/5.6
	5.10	Service brake		Hydraulic	Hydraulic	Hydraulic
	5.11	Parking brake		electric	electric	electric
	Electric engine	6.1	Drive motor rating S2 60 min	kW	16.6 AC	16.6 AC
6.2		Lift motor rating at S3 15%	kW	25.4 AC	25.4 AC	25.4 AC
6.3		Battery acc. to DIN 43 531/35/36 A,B,C, no		DIN 43536A	DIN 43536A	DIN 43536A
6.4		Battery voltage, nominal capacity K5	V/Ah	80/700	80/700	80/700
6.5		Battery weight	kg	1863	1863	1863
6.6		Battery dimensions	l/b/h(mm)	1028*855*784	1028*855*784	1028*855*784
6.7		Energy consumption acc. to VDI cycle	kWh/h	12.5	13	13.5
6.8		Min. battery weight	kg	1800	1800	1800
6.9		Max. battery weight	kg	1950	1950	1950
Addition data	8.1	Type of drive control		MOSFET/AC	MOSFET/AC	MOSFET/AC
		Manufacturer		CURTIS	CURTIS	CURTIS
	8.2	Operating pressure for attachments	bar	185	185	185
	8.3	Oil volume for attachments	l/min	65	65	65
	8.4	Sound level at the driver's ear according to EN / DIN 12 053	dB (A)	75	75	76
	8.5	Towing coupling, type DIN		φ24 Pin	φ24 Pin	φ24 Pin
9.1	Hydraulic Tank - capacity (drain & refill)	liter	46	46	46	

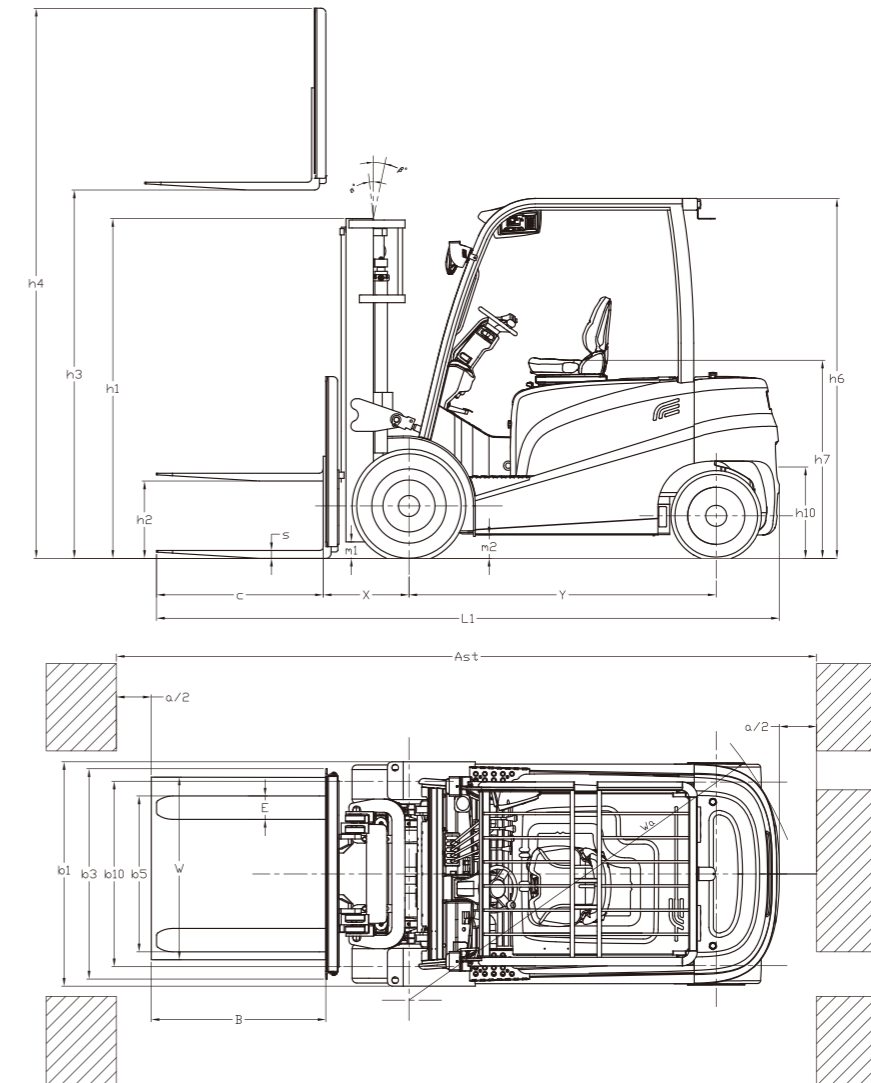

a=200 mm safety clearance
AST=a+Wa+ X+B

LOAD CHART

