

Distinguishing mark	1.1	Manufacturer	HANGCHA GROUP CO.,LTD.	
	1.2	Manufacturer's type designation	CPCD50-XXW99BN	
	1.3	Drive: electric (battery or mains), diesel, petrol, fuel gas	Electric	
	1.5	Rated capacity/rated load	Q (kg)	4990
	1.6	Load centre distance	c (mm)	500
	1.8	Load distance, centre of drive axle to fork	x (mm)	555
		Rear overhang	mm	447
	1.9	Wheelbas	y (mm)	1970
	Weigh	2.1	Service Weight	kg
2.2		Axle loading, laden front/rear	kg	10980/1240
2.3		Axle loading, unladen front/rear	kg	3335/3885
Tyres, chassis	3.2	Tyre size, front	28 x 12.5 x 15	
	3.3	Tyre size, rear	23 x 10 - 12	
	3.6	Tread, front	b10 (mm)	1166
	3.7	Tread, rear	b11 (mm)	1175
Dimensions	4.1	Tilt of mast/fork carriage forward/backward	$\alpha/\beta(^{\circ})$	6/6
	4.2	Height, mast lowered	h1 (mm)	2305
	4.3	Free lift	h2 (mm)	1478
	4.4	Lift	h3 (mm)	4800
	4.5	Height, mast extended	h4 (mm)	5860**
	4.7	Height of overhead guard (cabin)	h6 (mm)	2270
	4.20	Length to face of forks	l2 (mm)	3265
	4.21	Overall width	b1(mm)	1503
	4.22	Fork dimensions	s/e/l (mm)	1220x150x50
	4.31	Ground clearance, laden, below mast	m1 (mm)	170
	4.32	Ground clearance, centre of wheelbase	m2 (mm)	230
	4.35	Turning radius	Wa (mm)	2875
		Min. right angle stacking aisle width (Add load length and clearance)	mm	4630
	Performance data	5.1	Travel speed, laden/unladen	km/h
5.2		Lift speed, laden/unladen	m/s	0.430/-
5.3		Lowering speed, laden/unladen	m/s	0.500/-
5.5		Drawbar pull, laden/unladen	N	38500/-
5.7		Gradeability, laden/unladen*	%	23/-
Electric-engine	6.1	Drive motor rating S2 60 min	kW	16.6 AC
	6.2	Lift motor rating at S3 15%	kW	25.4 AC
	6.3	Battery acc. to DIN 43 531/35/36 A,B,C, no		DIN 43536A
	6.4	Battery voltage, nominal capacity K5	V/Ah	80/700
	6.5	Battery weight	kg	1863
	6.6	Battery dimensions	V/Ah	1028x855x784
	6.7	Energy consumption acc. to VDI cycle	kWh/h	13.5
	6.8	Min. battery weight	kg	1800
	6.9	Max. battery weight	kg	1950
Addition data	8.1	type of drive control		MOSFET/AC
		Manufacturer		CURTIS
	8.2	operation pressure for attachments	bar	185
	8.3	Oil volume for attachments	l/min	65
	8.4	Sound level at the driver's ear according to EN / DIN 12 053	dB (A)	76
	8.5	Towing coupling, type DIN		Φ24 Pin
9.1	Hydraulic Tank - capacity (drain & refill)	liter	46	

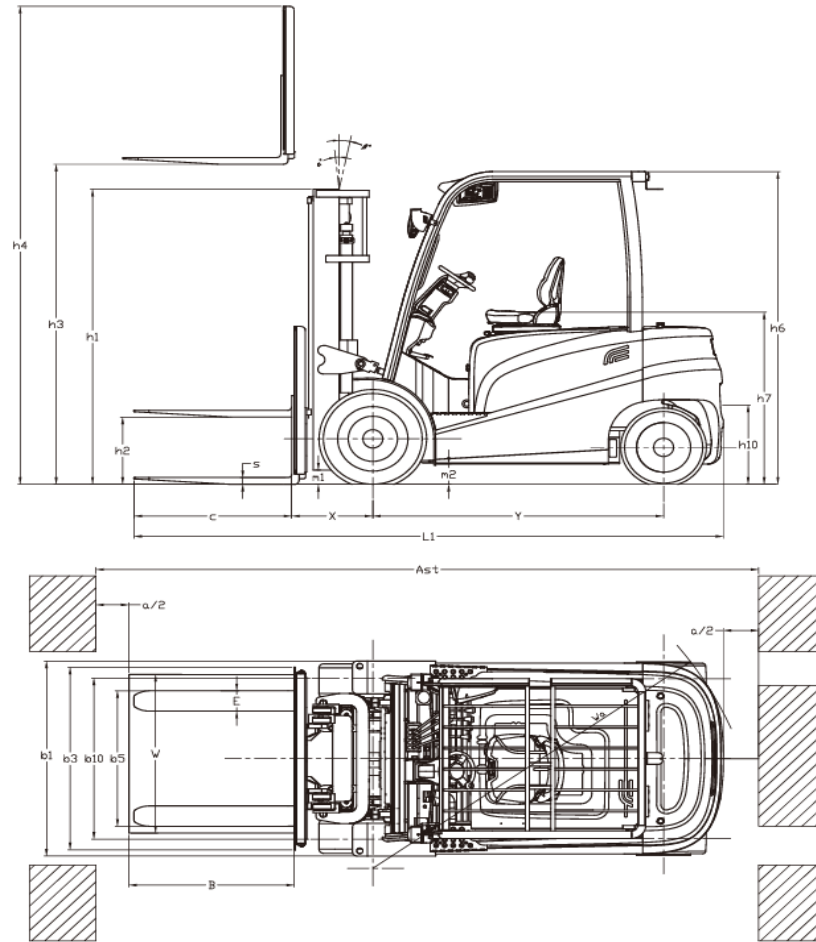

Note: \* With suspension seat or cabin \*\* Without backrest  
\* As a calculated value